

MiTek®

STUDLOK MkII

FAST METHOD OF FIXING
WALL PLATES TO STUDS

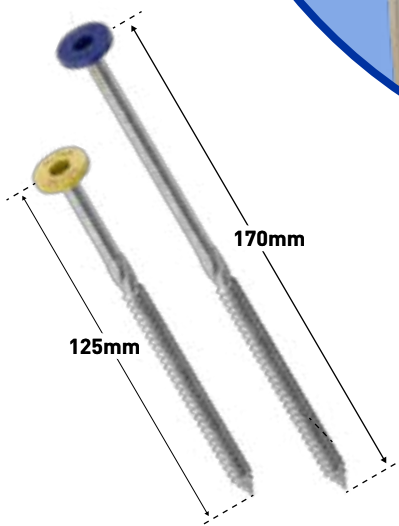
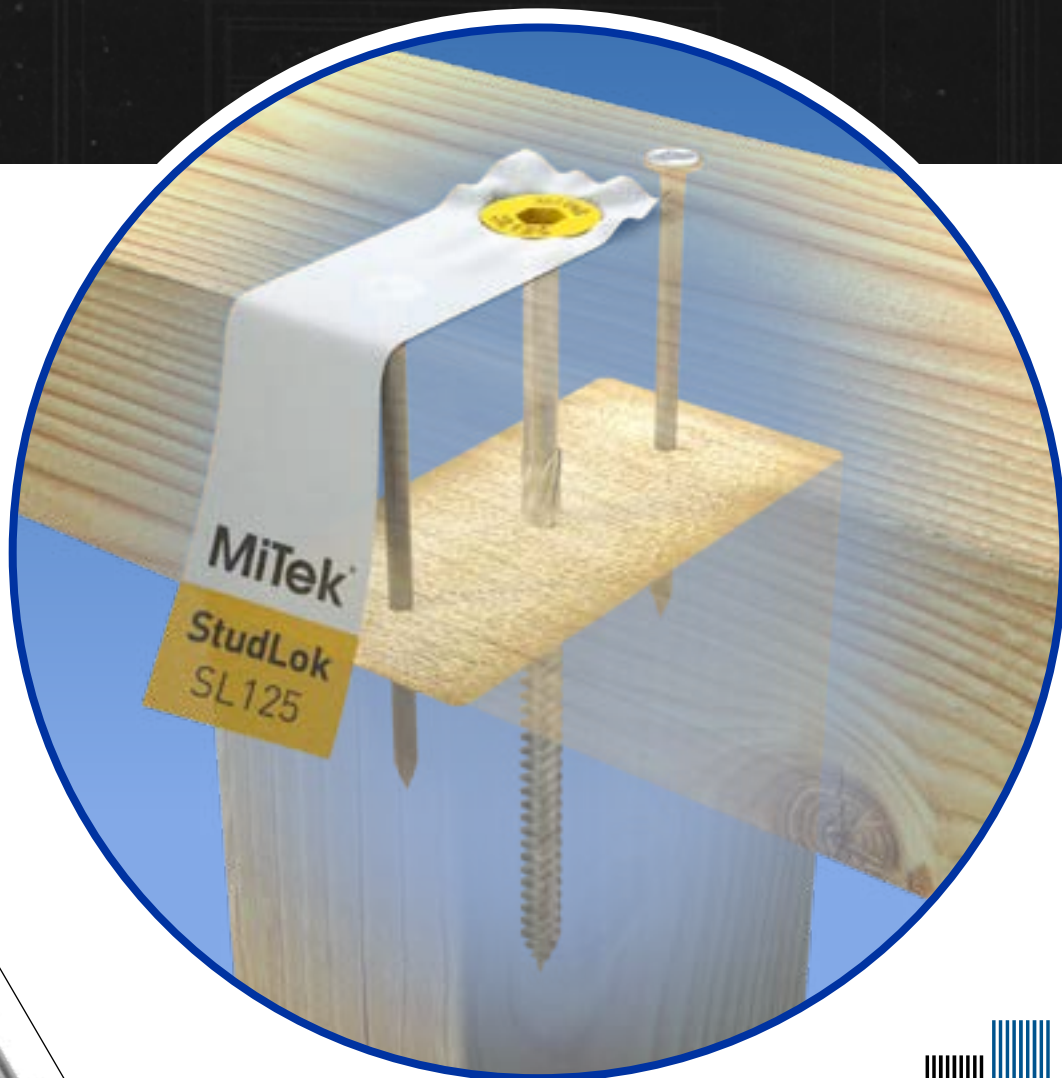

This Certified **Engineered Building Product** complies with the National Construction Code, Australian Standards & is CodeMark certified.



CODEMARK®

CM70055
Australia



APPLICATION:

Designed to provide a fast and easy way to connect wall plates to studs, StudLoks MkII come in two sizes to accommodate single or double wall plates.

ADVANTAGES

- Hexagonal socket head that suits standard 5mm drive bit.
- Hexagonal drive bit included in every box.
- Screw length and product identification stamped onto coloured head for easy inspection.
- Ultra smooth driving ability.
- Flat head sits flush with wall plate surface.
- Does not interfere with truss tie down fixing on side of wall frames.
- Zinc plated for corrosion resistance.
- Fully engineered and tested to Australian Standards.

SPECIFICATIONS:

Product Code	SL125
	SL170400

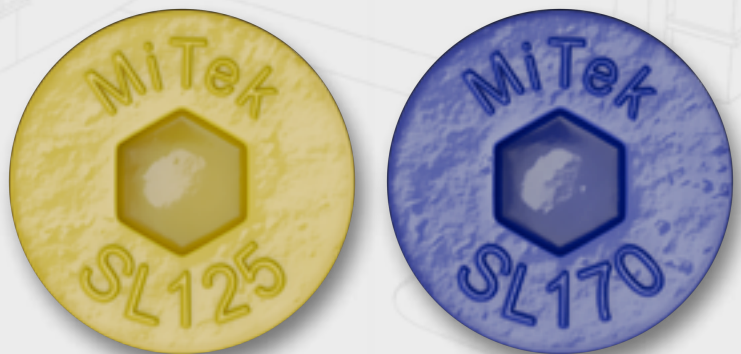

For durability information refer to [Corrosion Resistance of MiTek Metal Connectors](#), available on the MiTek website.

SL125 and SL170 StudLok MkII Screws are designed to suit single and double wall plates, respectively. Their withdrawal capacities may be enhanced by including the nail capacities shown in Table 1. The SL170 has a higher performance in thicker wall plate applications.

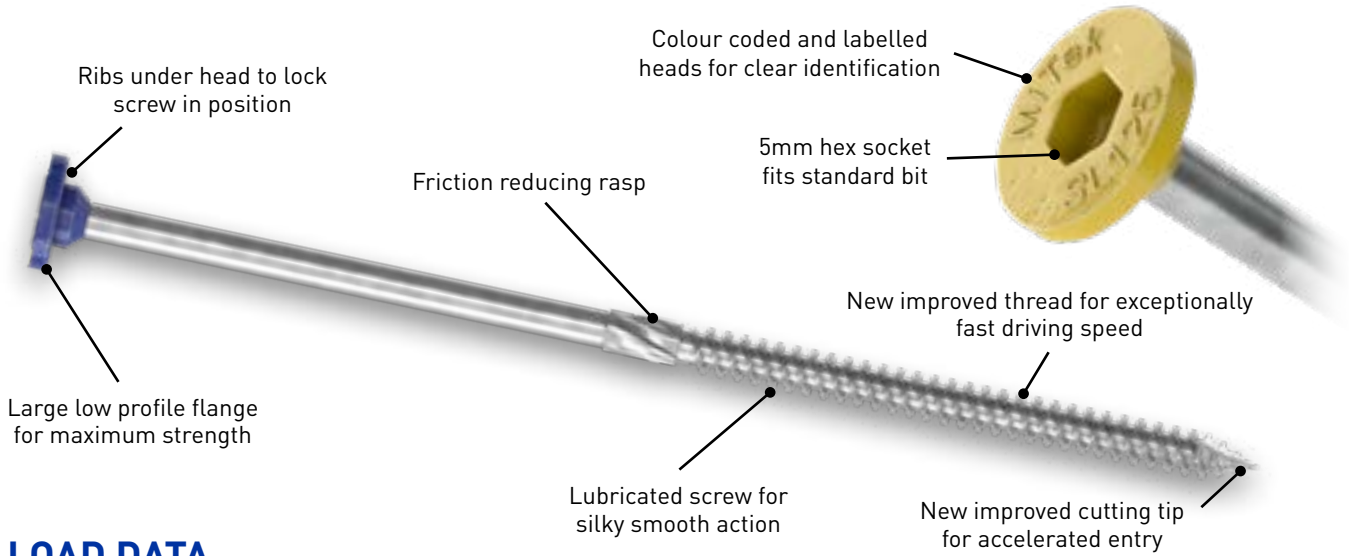

LOAD DATA

Table 1. Uplift Capacity of Wall Plates to Stud Fixings			
Timber Species / Joint Group	Wall Plate Thickness (mm)	Limit State Design Wind Uplift Capacity (kN) per StudLok MkII	
		SL125	SL170
Australian & New Zealand grown pine species / JD4	35	5.98	5.98
	45	5.98	5.98
	70	4.11	5.98
	80	3.37	5.98
	90	2.62	5.98
Australian & New Zealand grown pine species / JD5	35	4.81	4.81
	45	4.81	4.81
	70	3.31	4.81
	80	2.71	4.81
	90	2.11	4.81
Imported White Baltic Pine & European Spruce / JD6	35	3.58	3.58
	45	3.58	3.58
	70	2.46	3.58
	80	2.02	3.58
	90	1.57	3.58

Notes:

- The design capacities have been obtained and certified through laboratory testing – refer to MiTek Test Report No. 150405.
- The uplift design capacities of framing nails in Table 9.19 of AS 1684.2 and AS 1684.3 may be added to the StudLok MkII design capacities tabulated above. The design capacities of glue-coated or deformed shank pneumatically driven nails with minimum 40mm penetration into stud are shown on the right.

Timber Species / Joint Group	Limit State Uplift Design Capacity (kN) for pneumatically driven nails	
	Number/Nail diameter (mm)	
	2/ø3.05	2/ø3.33
JD4	0.26	0.33
JD5	0.17	0.20
JD6	0.12	0.14

StudLok MkII screws can also be used for fixing top plate directly to lintel and bottom plate to joist. Their design capacities are listed in Table 2.

Table 2. Uplift Capacity of Top Plate to Lintel and Bottom Plate to Floor Joist Fixings			
Timber Species / Joint Group	Wall Plate Thickness (mm)	Limit State Design Wind Uplift Capacity (kN) per StudLok MkII	
		SL125	SL170
Australian & New Zealand grown pine species / JD4	35	5.98	5.98
	45	5.98	5.98
	70	5.55	5.98
	80	4.54	5.98
	90	3.53	5.98
Australian & New Zealand grown pine species / JD5	35	4.81	4.81
	45	4.81	4.81
	70	4.45	4.81
	80	3.64	4.81
	90	2.83	4.81
Imported White Baltic Pine & European Spruce / JD6	35	3.58	3.58
	45	3.58	3.58
	70	3.31	3.58
	80	2.71	3.58
	90	2.11	3.58

Notes:

- Values in Table 1 and 2 incorporate the Category 1 capacity factor (ϕ) for houses. For other categories, multiply the design capacities by the following factors. Refer to AS 1720.1 for a full definition of each category.
- Values in Table 1 and 2 are neither suitable for fixing into end grain, nor edge grain of LVL, as timber splitting may occur.

Category	1	2	3
Adjustment factor	1.00	0.94	0.88

STUDLOK MKII FIXING - STANDARD WALLS

Drive StudLok MkII straight into centre of stud until flush with timber surface

MiTek recommends the use of all-weather colour-coded StudLok MkII labels for quick and easy identification and certification. Labels do not need to be held in place when driving. It is allowed to freely spin.

2 standard framing nails fixed into stud

Top plate

Single or double, 70mm or 90mm wall plates

Stud

Bottom plate

Available for
SL125 & SL170

StudLok
SL125

StudLok
SL170

RAKING WALLS

Drive StudLok MkII through the top plate into the centre of the stud.
Ensure StudLok MkII is flush.

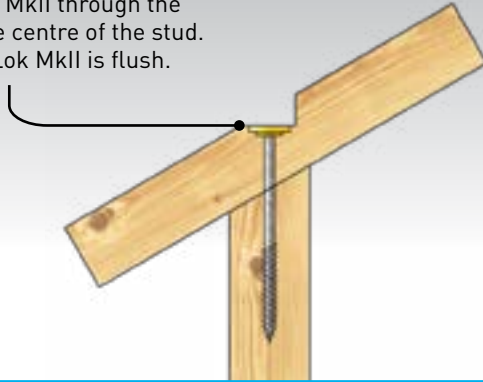

Centre Line



2 standard framing nails

FIXING TOP PLATE TO STUD

Fix ribbon plate to lower top plate in accordance with Clause 2.5 and 9.2.8 in AS 1684.2 and AS 1684.3.

Fix rafter/truss tie-down directly to lower top plate, lintel and/or stud with long and deep connectors such as CycloneTies, when SL170 is not used to fix the ribbon plate to stud.

StudLok SL125



Stud

Fix single Top Plate to Stud with StudLok SL125

Double Top Plate

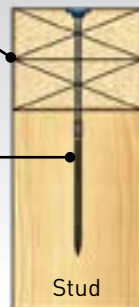

Stud

Fix double Top Plates to Stud with StudLok SL170 (recommended)

Ribbon Plate

Top Plate

StudLok SL125



Stud

Fix lower Top Plate to Stud with StudLok SL125 if Ribbon Plate is not required for Truss Tie-Down fixing (optional)

STUD AT END WALL & MULTIPLE STUD FIXINGS

Drive StudLok MkII straight through wall plate into centre of stud



Stud at End Wall

Drive StudLok MkII straight through wall plate into centre of each stud

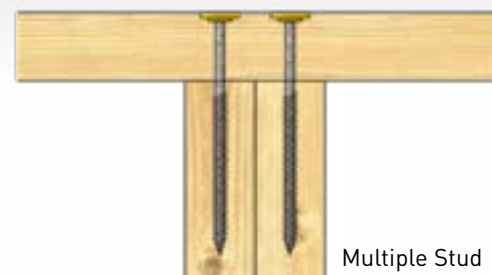
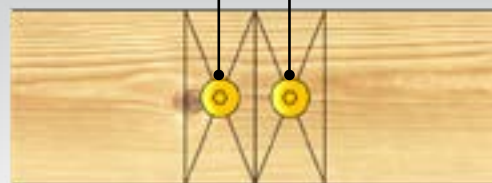

Multiple Stud

Structural Wall Bracing Plate to Stud Connections

StudLok MkII can be used in lieu of metal straps as required in AS1684.2 & 3, Table 8.18 and AS1684.4 Table 8.3. Refer to MiTek's Wall Plate to Stud Connections Reference Chart for details.

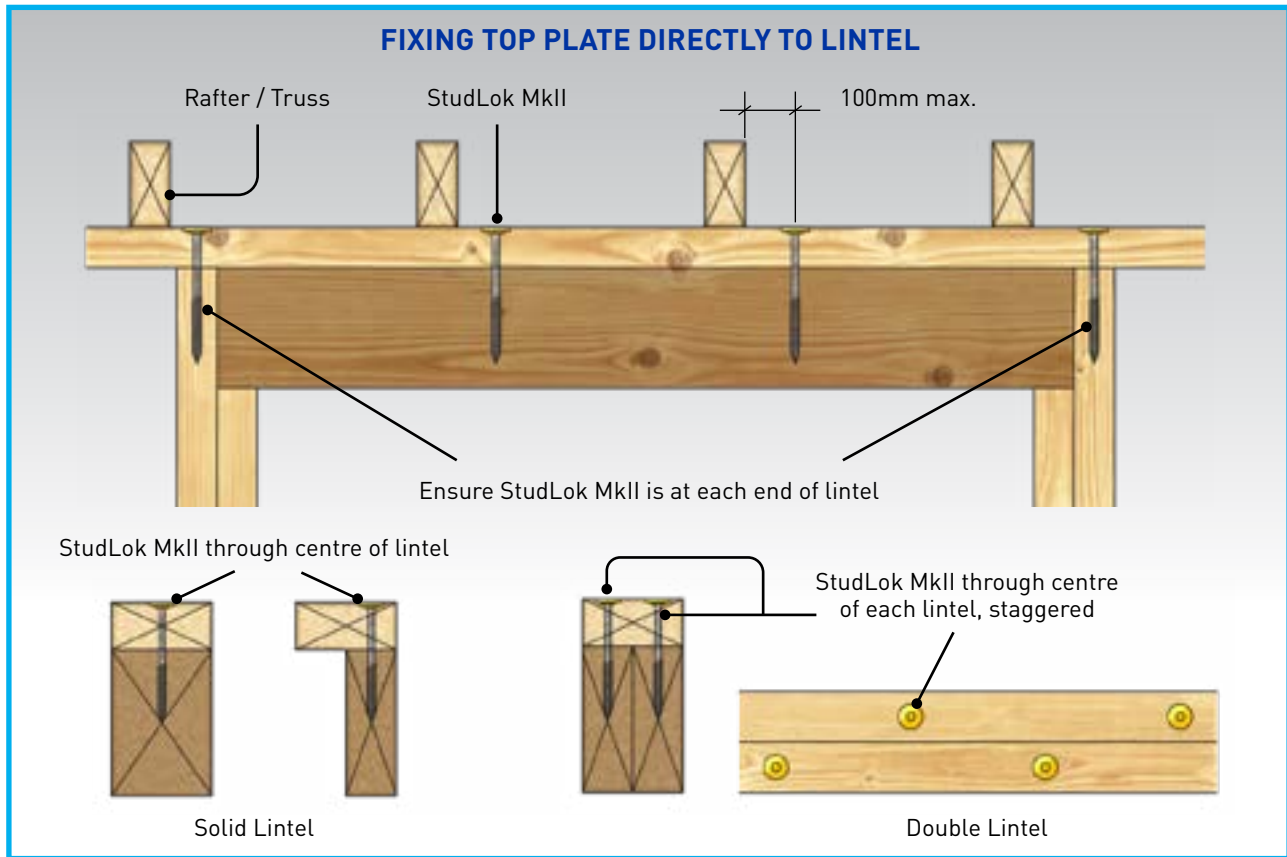

Notes:

1. Fix StudLok MkII through the top plate into lintel within 100mm max of each rafter / truss. Ensure design wind uplift capacity of StudLok MkII is equal to or greater than the uplift capacity to that required for the rafter / truss.
2. Tie-down of rafter / truss to top plate by others.

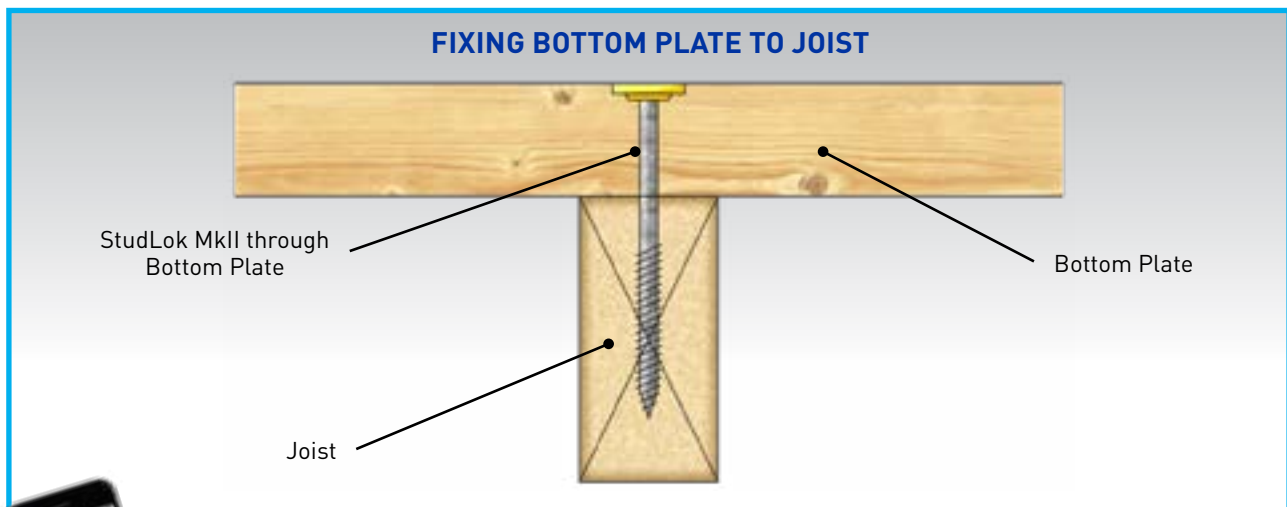

For more information about **MiTek's Engineered Building Products**, download the **FREE MiTek EasyCat App** or visit the MiTek website:

mitek.com.au

VIC +61 3 8795 8888 NSW +61 2 8525 8000 QLD +61 7 3861 2100 SA +61 8 8234 1326 WA +61 8 6279 8925
 NZ AKL +64 9 274 7109 NZ CHC +64 3 348 8691